



Setup Sheet for the Team Associated RC10T4

Driver Alain Lizotte

Track / City Centre du Hobby

Event Saison régulière Date 3/24/2019

**FRONT**

**SHOCK MOUNTING & CAMBER LINK**

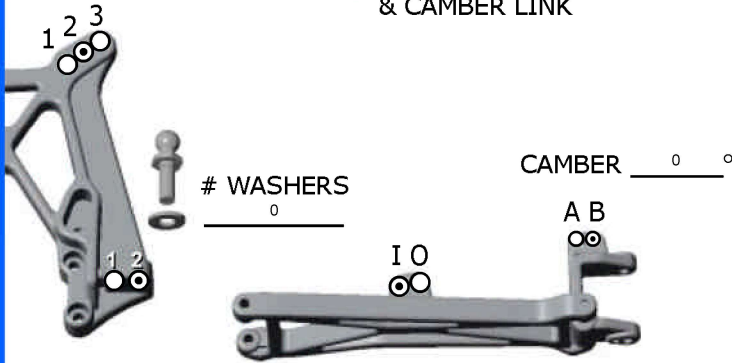

RIDE HEIGHT 25mm

TOE-IN (+)/OUT (-) 0°

BUMP STEER SPACER 2

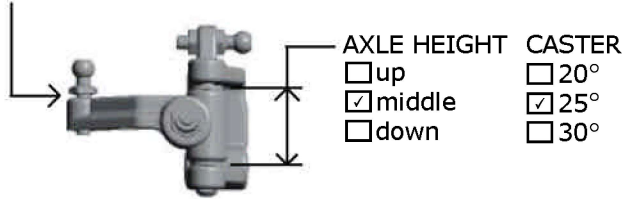

STEERING BLOCK  trailing  inline

**FRONT SHOCKS**

OIL 40 wt

SPRING (color) vert

PISTON # 2

SHAFT  unobtainium  STD

# LIMITERS 0

**FRONT TIRES & WHEELS**

FRONT TIRES Aka Chain Link

INSERTS Sock WHEELS Associated

TRACTION COMPOUND Super Soft (+ liquid wrench)

**REAR**

**SHOCK MOUNTING & CAMBER LINK**

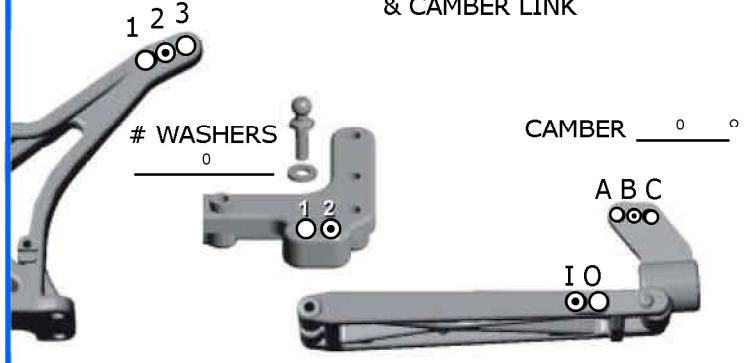

RIDE HEIGHT 25mm

**ANTI-SQUAT**

- 0°
- 1°
- 2°
- 3°

WHEELBASE  long  medium  short

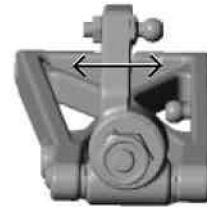

**ANTI-ROLL BAR**

- none
- black (soft)
- silver (med)
- gold (heavy)

**REAR SHOCKS**

OIL 30 wt

SPRING (color) vert

PISTON # 1

SHAFT  unobtainium  STD

# LIMITERS 0

**REAR TIRES & WHEELS**

REAR TIRES Aka Chain Link

INSERTS Stock WHEELS Associated

**RADIO/BATTERIES**

RADIO Futaba 4PX SERVO PowerHD WP-23KG

ESC Castle Creation Mamba X

DRAG BRAKE non INIT BRAKE n/a

BATTERIES LiPo 2S

BATTERY PLACEMENT: spacers in front 2 spacers in rear 1

**MOTOR**

MOTOR & WIND LRP Vector X12 7.5t

BRUSHES Brushless

SPRING n/a

PINION / SPUR 16 / 87

**OTHER**

BODY Proline

SPOILER Stock

CHASSIS Factory Team

**CONDITIONS**

- smooth  sandy
- bumpy  soft dirt
- low traction  grass
- med traction  blue groove
- high traction  clay
- wet  dusty
- dry  other

**COMMENTS**

NOTES Steering D/R: +84 / Brake D/R: 64

Steering expo: -25 / Throttle expo: -10 / Brake expo: -30

Torque (ch3): +100 /// 50% shock rebound

www.lemordudurc.com